

**PARTI DI
RICAMBIO**

FULLFLOW Rev. 2022

**SPARE
PARTS**

POMPE

PNEUMATICHE

s e r i e

FULLFLOW



DEBEM s.r.l. - Via Del Bosco, 41 - Busto Arsizio (VA) ITALY
Tel. (+39) 0331/074034 - fax (+39) 0331/074036 - info@debem.it - www.debem.com

POMPE PER L'INDUSTRIA

CHEMICAL / PAINTING / PRINTING / WATER TREATMENT / GALVANIC / TEXTILE / CERAMIC / AUTOMOTIVE / MECHANICAL / OIL & GAS

COSMETICS / TRICHOLOGICAL

info@debem.it - www.debem.com



DEBEM

MADE IN ITALY

ORDERING SPARE PARTS

ISTRUZIONI ORIGINALI FULLFLOW rev. 2022

Where are the Spare Parts Tables for the AISIBOXER series pumps.

The components of the AISIBOXER series pumps, in addition to fulfilling their primary function, are designed and manufactured to meet important general and fluid-processing safety functions; for the replacement of worn parts, use only Original spare parts suitable for the model and markings of the pump in question.



WARNING: danger of lack of safety

Failure to comply with the above can give rise to risks for the Operator, Technicians, people, pump and/or the environment where it is installed, that cannot be attributed to the Manufacturer. In addition, failure to comply with the safety instructions exposes the pump to dangerous contamination and, more generally, can lead to the safety requirements of the pump and the processed fluid being compromised for reasons not attributable to the manufacturer.

When ordering spare parts it is always necessary to include all the items shown in the example below:

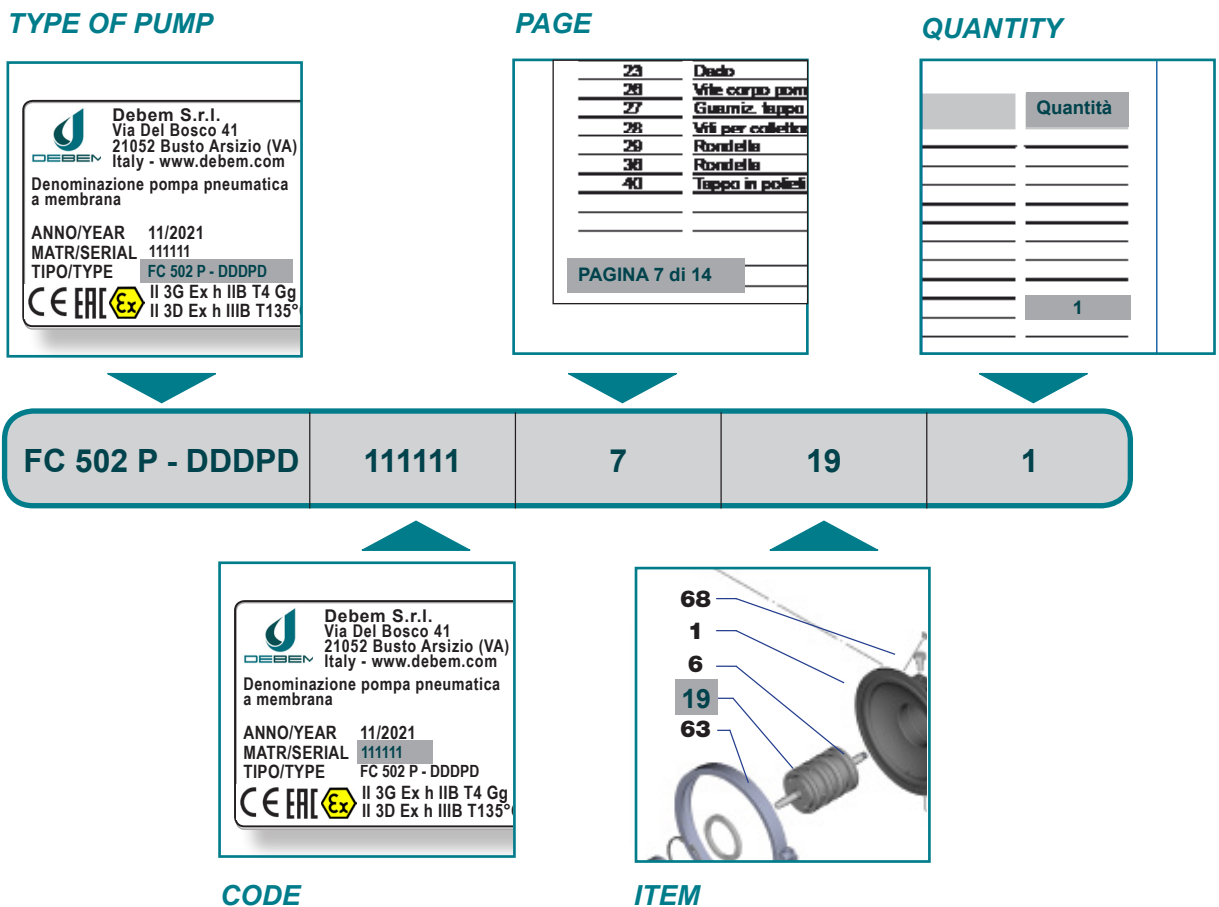

FULLFLOW 251 - Inox AISI 316L / AISI 316L Stainless Steel

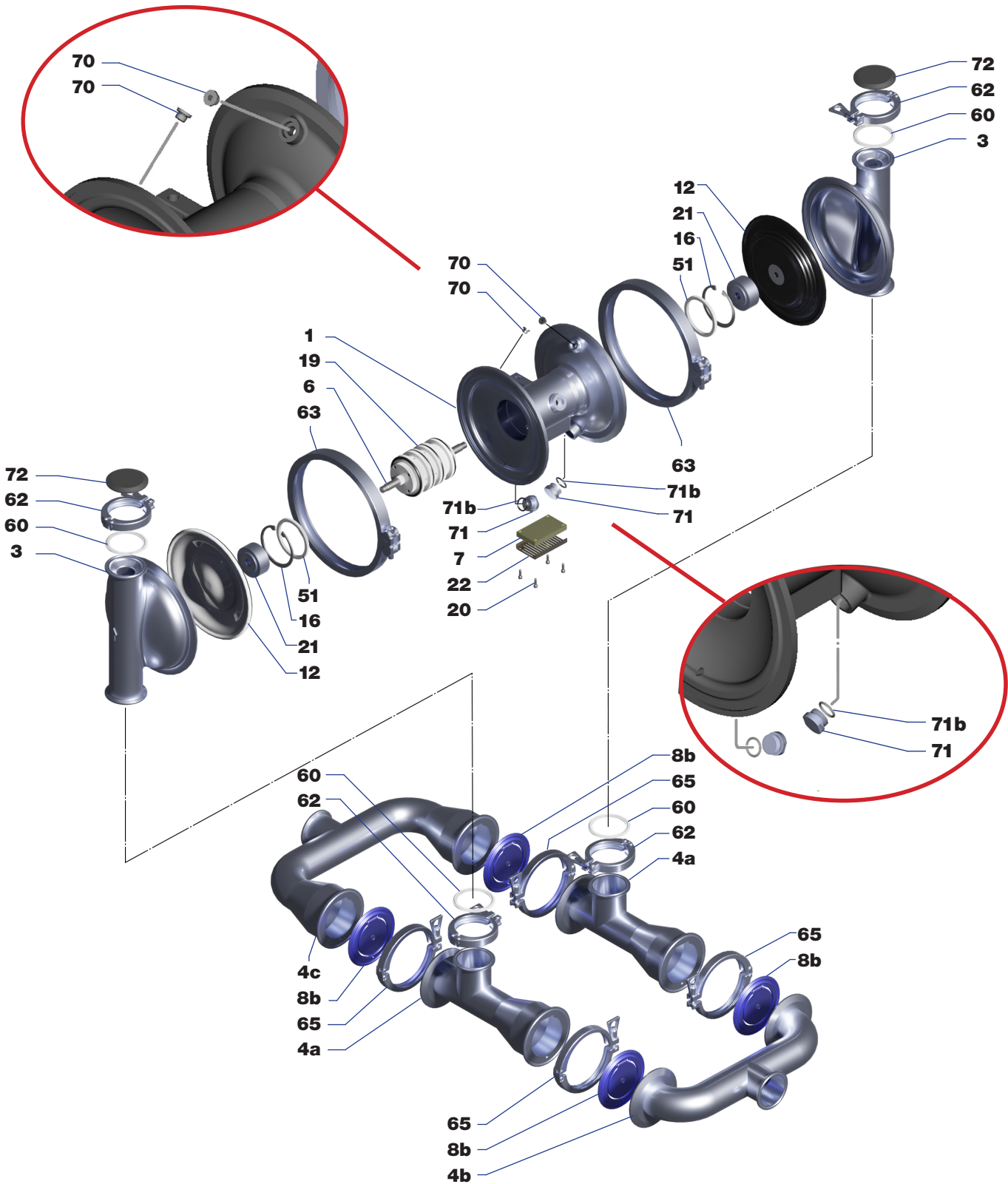

FULLFLOW 502 - Plastica / Plastic Made

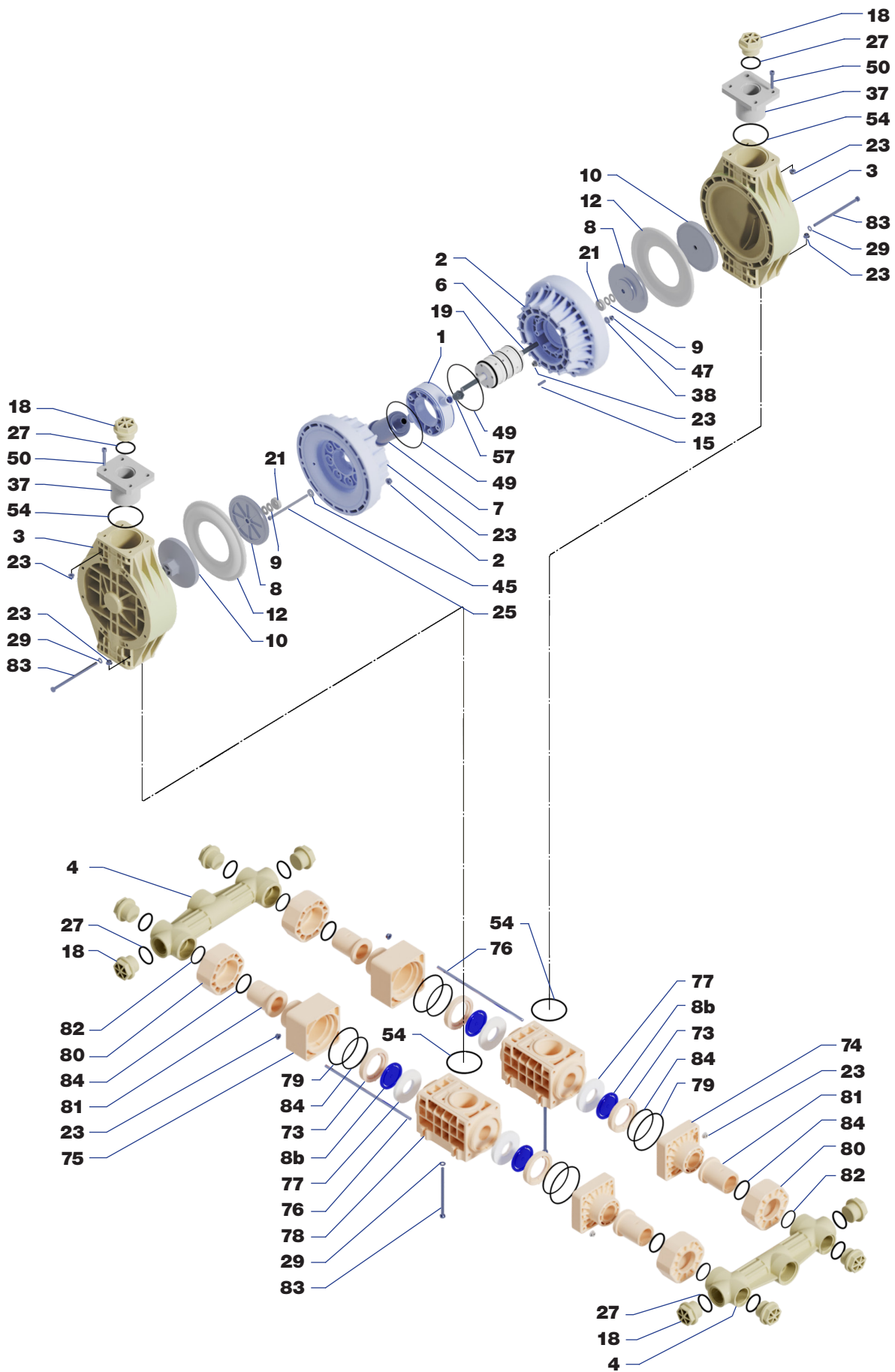

FULLFLOW 502 - Plastica / Plastic Made

Posizione	DESCRIZIONE	DESCRIPTION	Qtà
1	CORPO CENTRALE CON O-RING	CENTRAL HOUSING WITH ORING	1
2	FLANGIA LATO ARIA	FLANGE AIR SIDE	2
3	CORPO POMPA	PUMP CASING	2
4	COLLETTORE	MANIFOLD	2
6	ALBERO	SHAFT	1
7	FILTRO SILENZIATORE	SILENCER	1
8	PIATTELLO INTERNO	INTERNAL CAP	2
8b	PIATTELLO CLAPET	CLAPET	4
9	MOLLA A TAZZA	BELLEVILLE WASHER	4
10	CAPPELLOTTO	EXTERNAL CAP	2
12	MEMBRANA	DIAPHRAGM	2
15	SPINA	SPIN	4
18	TAPPO	CAP	10
19	SCAMBIATORE PNEUMATICO	PNEUMATIC EXCHANGER	1
21	DISTANZIALE	SPACER	2
23	DADO FLANGIATO	FLANGED NUT	48
25	VITE BLOCCO CENTRALE	CENTRAL HOUSING SCREW	8
27	GUARNIZIONE TAPPO	CAP GASKET	10
36	ROSETTA PIANA LARGA	FLAT WASHER	24
37	FLANGIA	FLANGE	2
38	MOLLA A TAZZA BLOCCO CENTRALE	CENTRAL HOUSING BELLEVILLE WASHER	8
45	ROSETTA PIANA LARGA BLOCCO CENTRALE	CENTRAL HOUSING FLAT WASHER	8
47	DADO FLANGIATO BLOCCO CENTRALE	CENTRAL HOUSING FLANGED NUT	8
49	O-RING BLOCCO CENTRALE	CENTRAL HOUSING GASKET	8
50	VITE PER FLANGIA	FLANGE SCREW	8
54	GUARNIZIONE O-RING 193	OR 193	2
57	RACCORDO RIDUZIONE INGRESSO ARIA	REDUCTON FITTING FOR AIR INLET	1
73	SEDE CAPLET	CLAPET SEAT	4
74	CONNESSIONE ASPIRAZIONE	INLET CONNECTION	2
75	CONNESSIONE MANDATA	OUTLET CONNECTION	2
76	TIRANTE	TIE ROD	8
77	ANELLO USURA CLAPET	CLAPET WEAR RING	4
78	CORPO VALVOLA	VALVE BODY	2
79	GUARNIZIONE O-RING 4512	OR 4512	4
80	GHIERA	LOCKING RING	4
81	COLLARE	NECK FLANGE	4
82	GUARNIZIONE O-RING 162	OR 162	4
83	VITE	SCREW	24
84	GUARNIZIONE O-RING 165	OR 165	4



RIVENDITORI Autorizzati:

CENTRI DI ASSISTENZA Autorizzati:

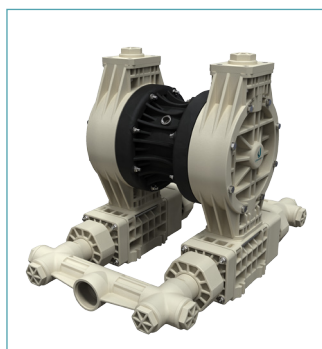

TIMBRO RIVENDITORE: _____